

FINISH RING				
PART NUMBER	OUTER PROFILE (IN.)	INNER PROFILE (IN.)	H1 (IN.)	H2 (IN.)
RT 36-24A1-2S	34X36	24X36	1	2

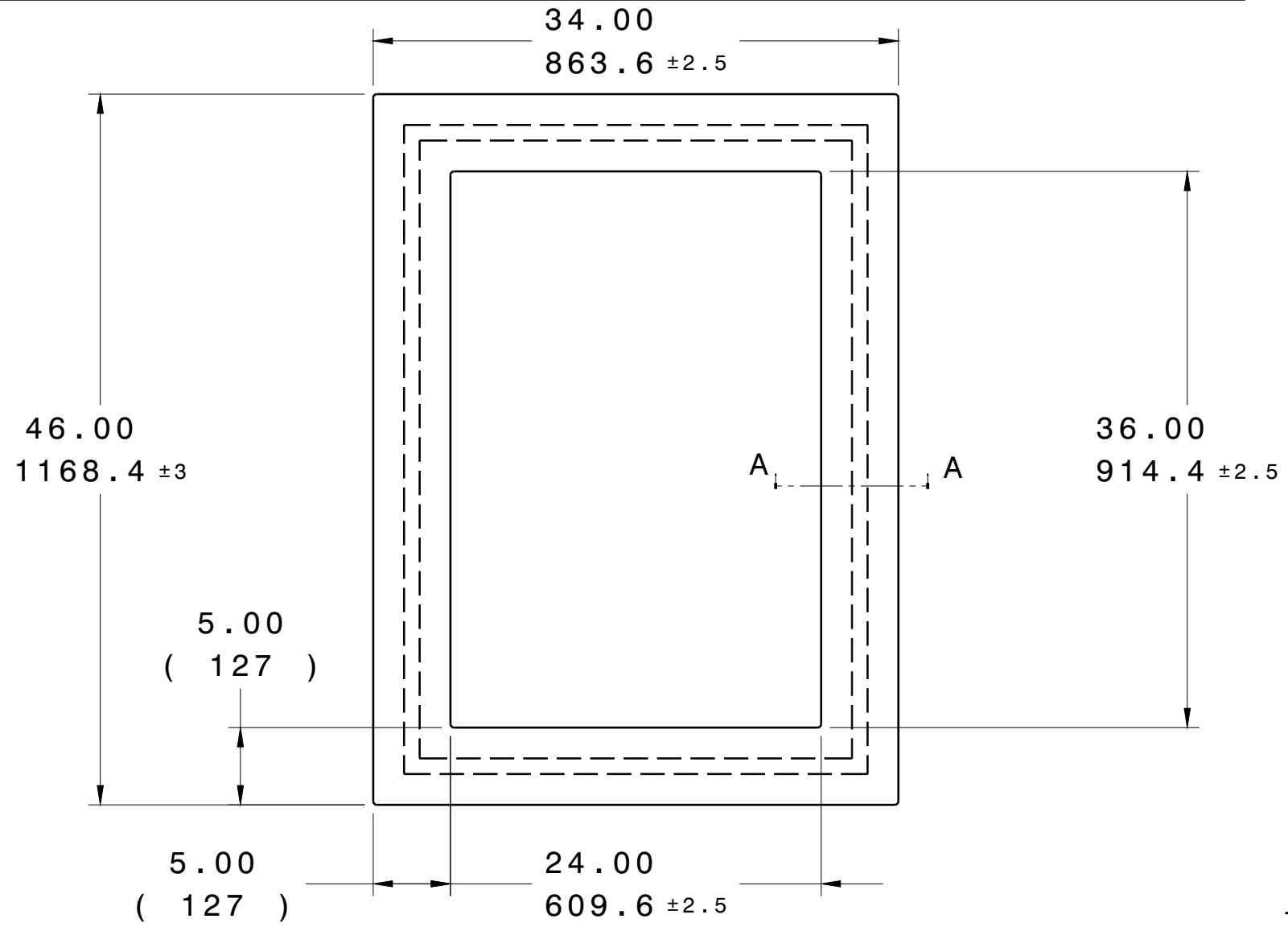

Front view  
Scale: 1:10

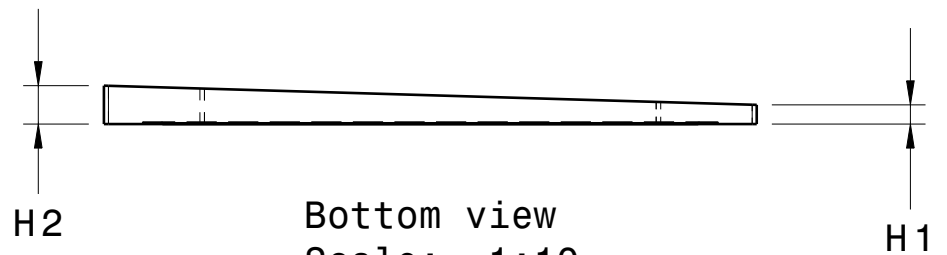

Bottom view  
Scale: 1:10

GENERAL NOTES:

- MEETS HS20/HS25 LOADING PER M306 PROOF LOAD
- ARPRO EXPANDED POLYPROPYLENE BLACK 120 G/L ASTM-D3575
- DENSITY/WEIGHT TOLERANCE = +/-10%

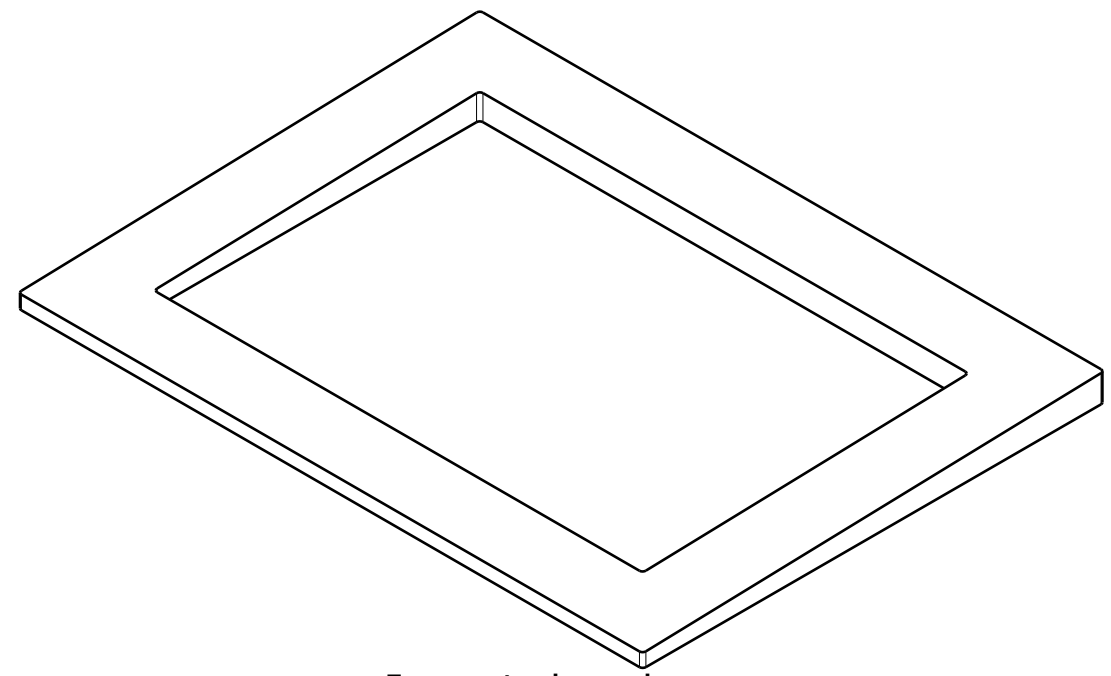

Isometric view  
Scale: 1:10

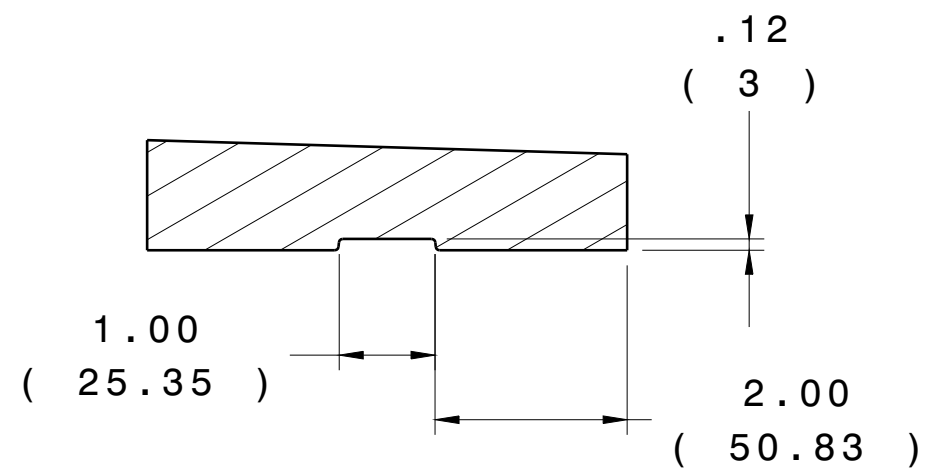

Section cut A-A  
Scale: 1:2

REV LEVEL	CHANGE DESCRIPTION	ECN #	DATE	INITIALS

	PART NUMBER: RT 36-24A1-2S	CUSTOMER REVISION LEVEL:
	ENGINEER:	PHONE NUMBER:

SURFACE PROFILE: 5.0mm A B M C M

NO BURRS AT PARTING LINE PORTION

ALL HOLES OR SLOT SIZE TOLERANCE: ± 0.5 MM

MATERIAL SPECIFICATION:  
3D CAD IS MASTER

	<small>ANY HARD COPY OF THIS DRAWING IS TO BE CONSIDERED AN UNCONTROLLED COPY UNLESS OTHERWISE SPECIFIED. ELECTRONIC COPY IS MASTER.</small>
<small>ENGLISH/INCHES UNLESS OTHERWISE SPECIFIED</small>	<b>Scale</b> 1:10
<small>CAD SYSTEM:</small> CATIA V5	
<small>MATERIAL:</small> EPP	
<small>FILENAME:</small>	

<small>DRAWN BY:</small>	<small>ENGINEERING:</small>	<small>MOLDING:</small>	<small>QUALITY:</small>