

FINISH RING				
PART NUMBER	OUTER PROFILE (IN.)	INNER PROFILE (IN.)	H1(IN.)	H2(IN.)
RT 36-24A1-2L	34X46	24X36	1	2

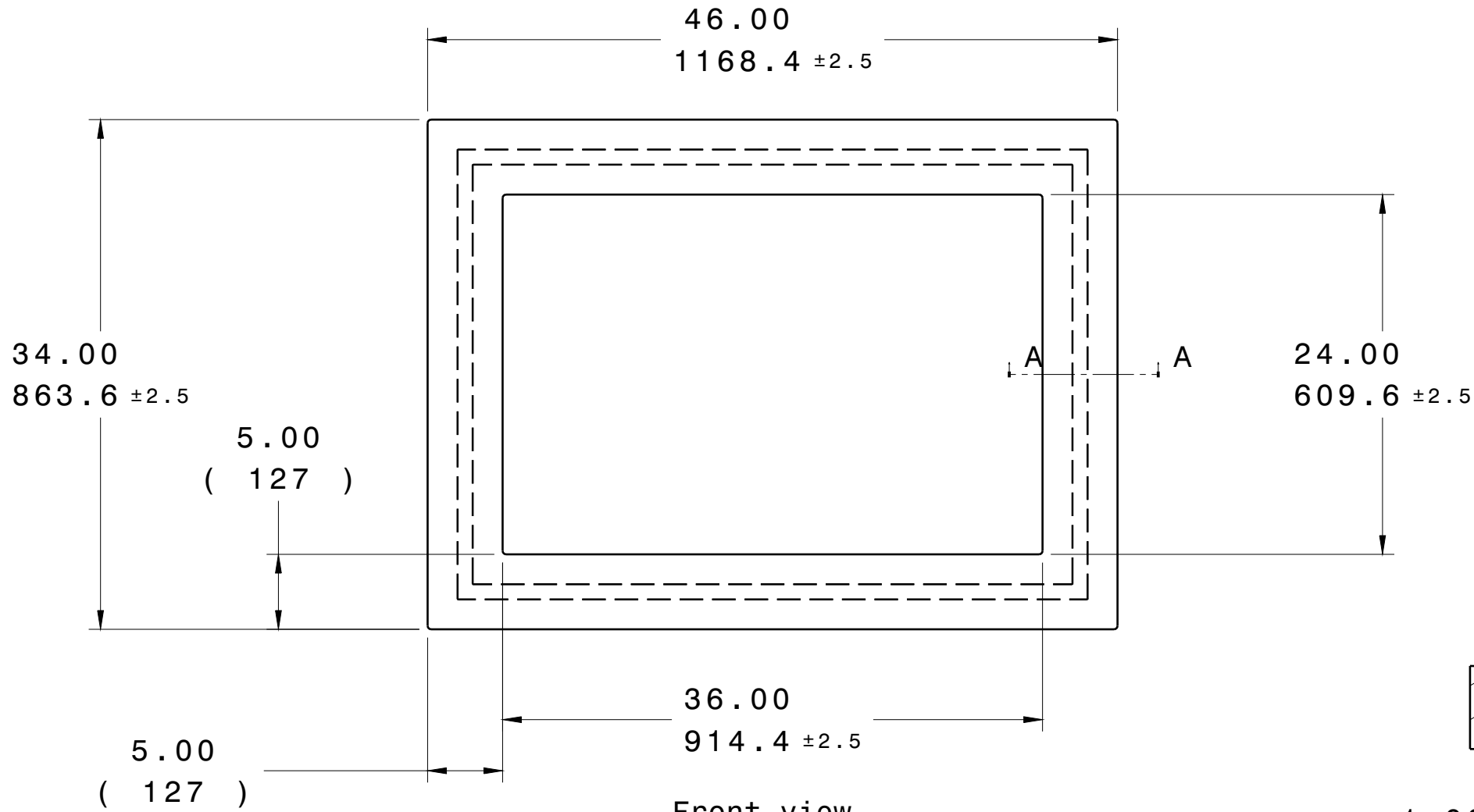

Front view
Scale: 1:10

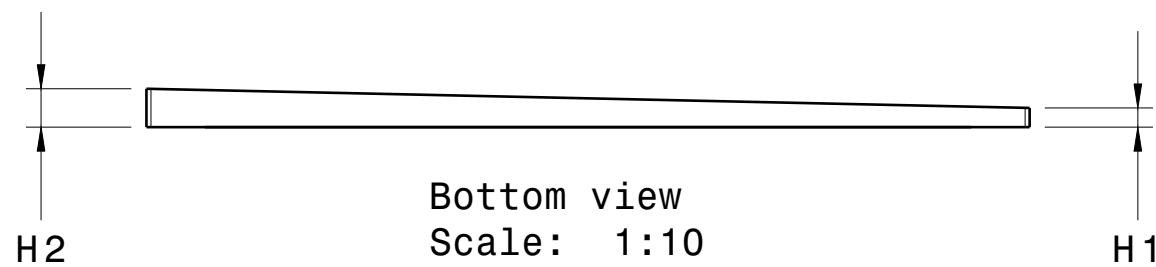

Bottom view
Scale: 1:10

GENERAL NOTES:

- MEETS HS20/HS25 LOADING PER M306 PROOF LOAD
- ARPRO EXPANDED POLYPROPYLENE BLACK 120 G/L ASTM-D3575
- DENSITY/WEIGHT TOLERANCE = +/-10%

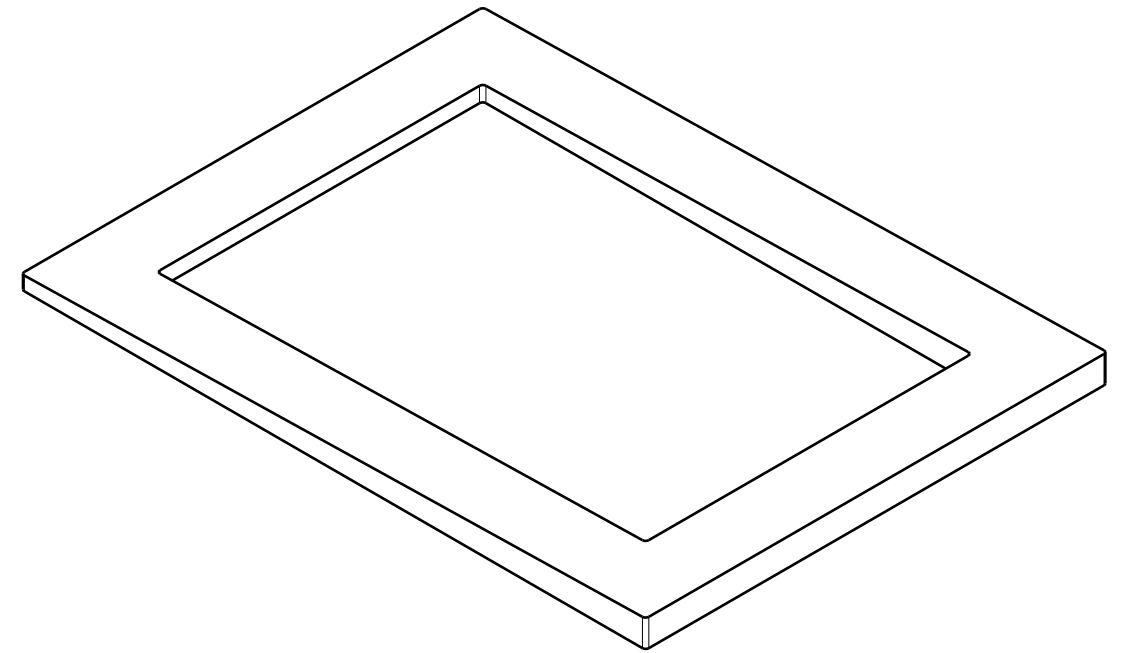

Isometric view
Scale: 1:10

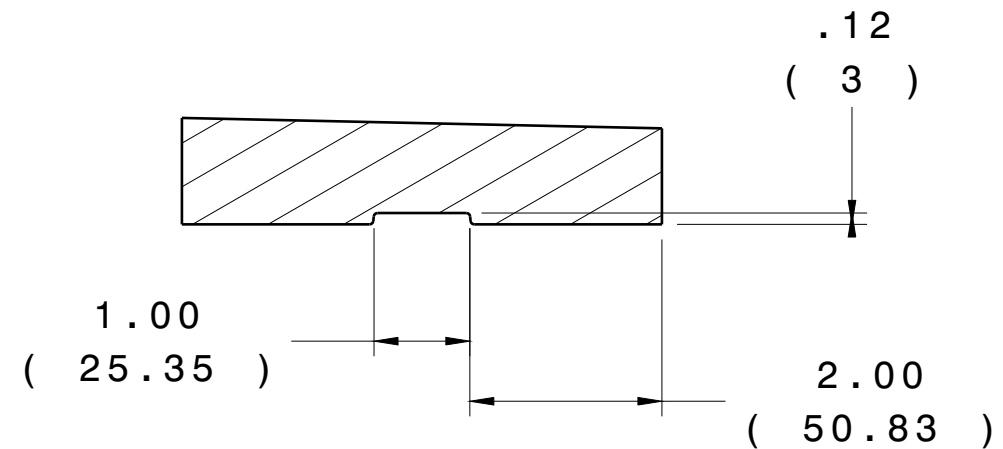

Section cut A-A
Scale: 1:2

REV LEVEL	CHANGE DESCRIPTION	ECN #	DATE	INITIALS
PRO-RING MANHOLE ADJUSTMENT SYSTEM		PART NUMBER: RT 36-24A1-2L	CUSTOMER REVISION LEVEL:	
		ENGINEER:	PHONE NUMBER	
DRAWN BY:	ENGINEERING:	MOLDING:	QUALITY:	
MATERIAL: EPP				
FILENAME:				

SURFACE PROFILE: 5.0mm A B C
 NO BURRS AT PARTING LINE PORTION
 ALL HOLES OR SLOT SIZE TOLERANCE: ± 0.5 MM
 MATERIAL SPECIFICATION:
 3D CAD IS MASTER

Scale 1:10
 CAD SYSTEM: CATIA V5
 MATERIAL: EPP
 FILENAME:

ANY HARD COPY OF THIS DRAWING IS TO BE CONSIDERED AN UNCONTROLLED COPY UNLESS OTHERWISE SPECIFIED. ELECTRONIC COPY IS MASTER