

# INTERNAL JOINT SEAL

Stops groundwater infiltration

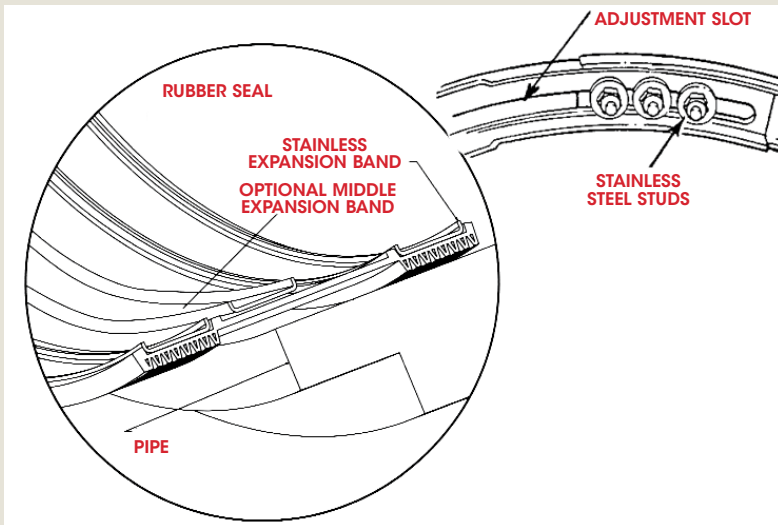

## ADVANTAGES:

- Easily installed by a two person crew.
- Conforms to out-of-round shapes.
- Teardrop sealing fins provides superior sealing.
- Provides watertightness, while having the flexibility to allow differential movement of the pipe sections caused by ground movement and frost lift.
- Installed mechanically to the inside of existing pipe.
- Reusable – can be removed and used elsewhere if needed.
- Constructed of high quality materials having a long service life.

**THE INTERNAL JOINT SEALS** are watertight compression seals that reduce groundwater infiltration, increasing waste water treatment capacity in underground pipes. Made of high quality rubber, Internal Joint Seals meet or exceed the physical requirements of ASTM C-923. The stainless steel expansion band to be used meets or exceeds ASTM A-240, Type 304 standards. Designed for new or existing installations, excavation is not necessary for use.

**RUBBER SLEEVE** Made of 7-1/2 inch wide high quality rubber, the Internal Joint Seal meets or exceeds the physical requirements of ASTM C-923 as modified with a minimum 3/16 inch thickness for durability and resistance to puncturing or tearing.

**EXPANSION BANDS** The identical two piece channeled expansion bands are 1 3/4 inches wide and are fabricated from high quality, corrosion resistant, 16 gauge stainless steel conforming to the requirements of ASTM A-240, Type 304. The 8 inch long adjustment slot on the end of each band provides for a 2 inch diameter range. An easy to use mechanical expansion tool, alternately inserted in each adjustment slot, quickly expands the band to compress the rubber sleeve against each section of pipe. Once expanded, the band is locked in place by the tightening of 2 sets of 3 self locking stainless steel studs, providing a flexible watertight seal.



# SPECIFICATIONS

## GENERAL

When required in the contract document, the Contractor shall provide all labor, equipment and materials to seal joints subjected to 14 feet or less of head with an internal rubber seal manufactured by Cretex Specialty Products, Waukesha, WI, [www.cretexseals.com](http://www.cretexseals.com) or approved equal.

## PRODUCTS

### INTERNAL RUBBER SEAL

Internal rubber seals used for sealing joints shall consist of the following components.

### RUBBER SLEEVE

The flexible rubber sleeve shall be extruded from a high-grade rubber compound conforming to the applicable requirements of ASTM C-923, with a minimum 1500-psi tensile strength, maximum 18% compression set, and a hardness (durometer) of 48±5.

The sleeve shall be available in 7.5 inches with a minimum thickness of 3/16 inches and shall be capable of expansion when installed of not less than 2 diameter inches. The sleeve shall contain two integrally formed expansion band recesses and multiple sealing fins.

Any splice used to fabricate the sleeve shall be vulcanized and have a strength such that the sleeve shall withstand a 180 degree bend with no visible separation.

### EXPANSION BANDS

The two or four piece expansion bands used to compress the sleeve against the pipe shall be 16 gauge stainless steel conforming to ASTM A-240, Type 304, with a minimum width of 1-3/4 inches.

The expansion mechanisms shall have the capacity to develop the pressures necessary to make a watertight seal and shall have a minimum adjustment range of 2 diameter inches. Stud and nuts used for this mechanism shall be stainless steel conforming to ASTM F-593 and 594, Type 304.

### OPTIONAL MIDDLE EXPANSION BAND

The two or four piece middle band used to prevent excessive ballooning of the sleeve caused by hydrostatic pressure, shall meet the same requirements as stated above 2.03 Expansion Bands.

## INSTALLATION

The surface of the pipe extending approximately 5 inches on either side of the joint shall be reasonably smooth, non-porous and free of any lime or other deposits, loose material and excessive voids. Any voids, cracks or porous surfaces shall be repaired with the appropriate material.

After the rubber sleeve has been placed in the proper position, two or four piece stainless steel expansion bands shall be installed in the band recesses and individually tightened as required to provide a watertight seal.

Detailed installation procedures shall be in accordance with the manufacturers instructions.

## PHYSICAL PROPERTIES

<b>Tensile Strength</b> .....	<b>1500 psi</b>
<b>Elongation at break</b> .....	<b>350% min.</b>
<b>Hardness (Durometer)</b> .....	<b>48+5</b>
<b>Accelerated oven-aging</b> .....	<b>max. 15% decrease of tensile, 20% of elongation</b>
<b>Chemical resistance</b> .....	<b>no weight loss in 1 N of sulfuric or hydrochloric acid</b>
<b>Compression set</b> .....	<b>18% max. decrease</b>
<b>Water absorption</b> .....	<b>max. 10% increase by weight</b>
<b>Ozone resistance</b> .....	<b>rating 0</b>
<b>Low temperature brittle point</b> .....	<b>No fracture at -40°C.</b>
<b>Tear resistance</b> .....	<b>200 lb. f/in.</b>
<b>Splice strength</b> .....	<b>180° bend with no visible separation</b>

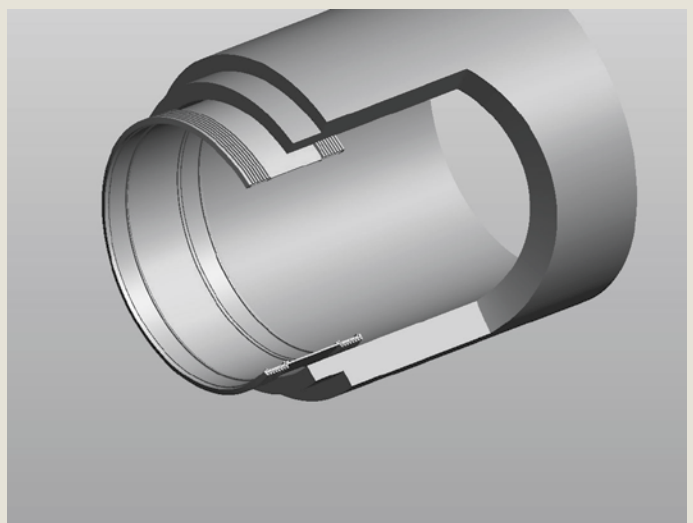

## **SUGGESTED SPECIFICATIONS FOR INTERNAL JOINT SEALS**

### **PART 1 GENERAL**

#### **1.01 GENERAL**

When required in the contract document, the Contractor shall provide all labor, equipment and materials to seal pipe joints subjected to 20 feet or less of head with an internal rubber seal manufactured by Cretex Specialty Products, Waukesha, WI, [www.cretexseals.com](http://www.cretexseals.com) or approved equal.

### **PART 2 PRODUCTS**

#### **2.01 INTERNAL RUBBER SEAL**

Internal rubber seals used for sealing joints shall consist of the following components.

#### **2.02 RUBBER SLEEVE**

The flexible rubber sleeve shall be extruded from a high-grade rubber compound conforming to the applicable requirements of ASTM C-923, with a minimum 1500-psi tensile strength, maximum 18% compression set, and a hardness (durometer) of 48±5.

The sleeve shall be available in a 7.5 inch width with a minimum thickness of 3/16 inches and shall be capable of expansion when installed of not less than 2 diameter inches. The sleeve shall contain two integrally formed expansion band recesses and multiple sealing fins.

Any splice used to fabricate the sleeve shall be vulcanized and have a strength such that the sleeve shall withstand a 180 degree bend with no visible separation.

#### **2.03 EXPANSION BANDS**

The two or four piece expansion bands used to compress the sleeve against the pipe shall be 16 gauge stainless steel conforming to ASTM A-240, Type 304, with a minimum width of 1¾ inches.

The expansion mechanisms shall have the capacity to develop the pressures necessary to make a watertight seal and shall have a minimum adjustment range of 2 diameter inches. Studs and nuts used for this mechanism shall be stainless steel conforming to ASTM F-593 and 594, Type 304.

#### **2.04 OPTIONAL MIDDLE EXPANSION BAND**

The two or four piece middle band used to prevent excessive ballooning of the sleeve caused by hydrostatic pressure, shall meet the same requirements as stated above 2.03 Expansion Bands.

### **PART 3 INSTALLATION**

#### **3.0 INSTALLATION**

The surface of the pipe extending approximately 5 inches on either side of the joint shall be reasonably smooth, non-porous and free of any lime or other deposits, loose material and excessive voids. Any voids, cracks or porous surfaces shall be repaired with the appropriate material.

After the rubber sleeve has been placed in the proper position, two or four piece stainless steel expansion bands shall be installed in the band recesses and individually tightened as required to provide a watertight seal.

Detailed installation procedures shall be in accordance with the manufacturers instructions.



# INTERNAL JOINT SEAL INSTALLATION INSTRUCTIONS

1. Wire brush the pipe surface 5 inches on either side of the leaking joint to remove lime and other deposits. Wipe this area with mortar, filling the cracks and porous surface, providing a smooth sealing surface. **PREPARATION OF THIS SURFACE IS ABSOLUTELY NECESSARY.**
2. Make a series of alignment marks around the pipe 4 inches away from the joint and install rubber sleeve so it is positioned along alignment marks and centered over the joint.
3. LUBRICATE all bands and assemble in pipe by overlapping 2 band ends such that the studs of each band lay behind and extend through the other band's adjustment slot.
4. Position bands in the band recess of the sleeve, center studs in each adjustment slot and tighten lock nuts (3) on one side of band only. To generate the force necessary to provide a watertight seal, bands must be expanded at both adjustment slots.
5. Place the installation tool in the opposite adjustment slot, as shown below, and expand the band until tight. Check to insure that the sleeve is tight against the surface around its entire perimeter, check tool tightness and tighten the 3 lock nuts.
6. Remove tool and place in first adjustment slot. Expand tool, as needed, to prevent slippage while lock nuts are loosened. Expand, as necessary, to provide a watertight seal. Securely tighten the 3 lock nuts.
7. Repeat band installation procedure for each band.
8. Repeat band installation procedure for the middle band if required.

**NOTES:**

1. A smooth, non-porous sealing surface must be prepared.
2. Do not use if water pressure head is expected to exceed 14 feet.

