

PRO-CUTTER Model 1060

Manhole Cutter For Track and Skid Loaders
Specifications and Dimensions



Distributed by **Cretex Specialty Products** and manufactured by Elk River Machine Company, the **PRO-CUTTER Model 1060** sets a new standard for performance, quickly paying for itself by drastically reducing the time and labor required to remove a manhole frame from asphalt or concrete pavement.

PRO-CUTTER Model 1060

- Rapidly cuts a clean 60" diameter hole through asphalt or concrete
- Available with carbide or diamond bits
- Dry or wet cut
- Electric over hydraulic controls operated by joystick mounted push-buttons
- Adjustable automatic feed rate
- Integral guards for safe operation
- Robust design and construction for years of reliable service

Cretex Specialty Products
N16 W23390 Stoneridge Drive A
Waukesha, WI 53188



Phone: (262) 542-8153
Toll Free: (800) 345-3764
Fax: (262) 542-0301
Website: www.cretexseals.com

PRO-CUTTER Model 1060
Manhole Cutter For Track and Skid Loaders
Specifications and Dimensions

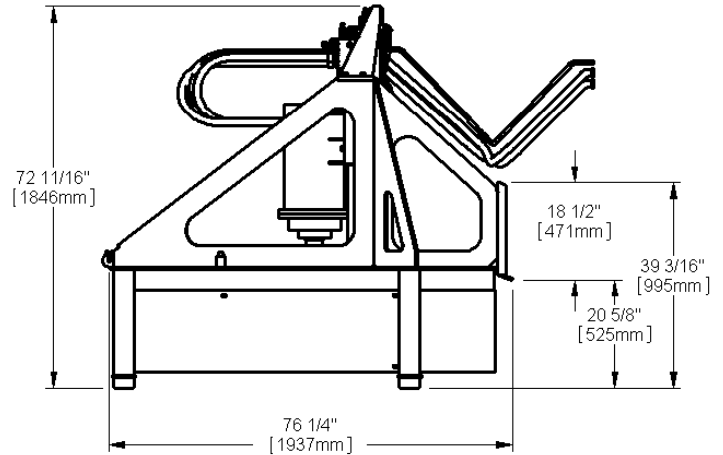
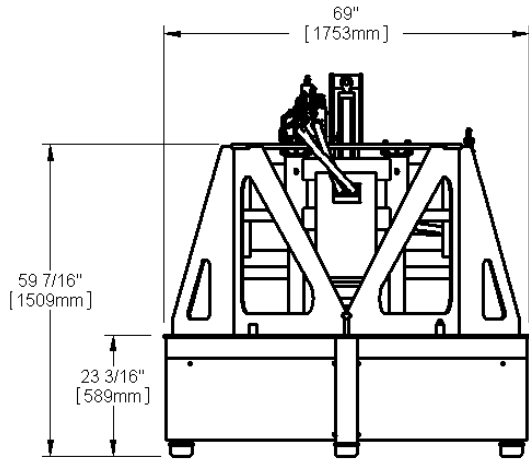

PRO-CUTTER Model 1060 Specifications

Operating Weight:	2,640 lb. (1,198 kg)
Base Unit Weight (no bit):	1,980 lb. (898 kg)
Maximum Cut Diameter:	60 in (1.52 m)
Maximum Cut Depth:	14.5 in (368 mm)
Maximum Cutting Torque:	5,265 ft-lb (7,138 N-m)

Options

Cutting Bits:

- 60" Carbide (for asphalt pavement)
- 60" Diamond (for concrete or asphalt pavement)
- Smaller diameter bits available on request

Electrical Power Harness - Loader Specific

Hydraulic adapters - Loader Specific

Track or Skid Loader Requirements

Loader attachment plate:	Universal 1994
Rated Operating Lift Capacity:	2,900 lb. (1315 kg)
Remote Hydraulics (High Flow):	25 - 40 gpm (114 - 151 l/min)
Remote Hydraulics Working Pressure:	3,000 psi max (207 bar)
Remote Case Drain Return Line:	5 gpm (18.9 l/min)
3 Intermittent Electrical Control Buttons (on Joystick):	12 VDC / 1.7 A (each)

Cretex Specialty Products
 N16 W23390 Stoneridge Drive A
 Waukesha, WI 53188



Phone: (262) 542-8153
Toll Free: (800) 345-3764
Fax: (262) 542-0301
Website: www.cretexseals.com